

AC6958B Datasheet

Zhuhai Jieli Technology Co.,LTD

Version: 1.6

Date: 2026.04.07

Copyright © Zhuhai Jieli Technology Co.,LTD. All rights reserved.

AC6958B Features

CPU

- 32-bit DSP supports hardware Float Point Unit(FPU)
- Up to 240MHz programmable processor
- 64 Vectored interrupts
- 8 Levels interrupt priority

DSP Audio Processing

- SBC, AAC Audio decodes supported for BT audio
- mSBC voice codecs supported for BT phone
- Supports MP2, MP3, WMA, APE, FLAC, AAC, MP4, M4A, WAV, AIF, AIFC audio decoding
- Packet Loss Concealment (PLC) for voice processing
- Acoustic echo cancellation/suppression (AEC,AES)
- Single/Dual MIC Environmental Noise Cancellation (ENC)
- Multi-band DRC limiter
- 20-band EQ configuration for voice Effects

Audio Codec

- One channels 16-bit DAC, SNR >= 95dB
- Three channels 16-bit ADC , SNR >= 90dB
- Sampling rates of 8KHz/11.025KHz/16KHz/22.05KHz/24KHz/32KHz/44.1KHz/48KHz are supported
- One analog MIC amplifier, build-in MIC bias generator
- Supports two PDM digital MIC inputs
- three channels analog MUX
- Supports cap-less, single-ended, and differential mode at the DAC path
- Supports 16ohm and 32ohm Speaker loading

Bluetooth

- Compliant with Bluetooth V6.0+BR+EDR+BLE specification (DN Q334307)

- Meet class2 and class3 transmitting power requirement
- Support GFSK and $\pi/4$ DQPSK all packet types
- Provides +6dbm transmitting power
- receiver with -90dBm sensitivity
- Fast AGC for enhanced dynamic range
- Supports a2dp\avctp\avdtp\avrcp\hfp\spp\smp\att\gap\gatt\rfcomm\sdp\l2cap profile
- a2dp 1.4\avctp 1.4\avdtp 1.3\ avrcp 1.6.3\hfp 1.9\spp 1.2\rfcomm 1.2\pnp 1.3\hid 1.1.1\sdp core 6.0\l2cap core 6.0

Peripherals

- One full speed USB 2.0 OTG controller
- Four multi-function 16-bit timers, support capture and PWM mode
- Three 16-bit PWM generator for motor driving
- Three full-duplex basic UART, UART0 and UART1 supports DMA mode
- Two SPI interface supports host and device mode
- One hardware IIC interface supports host and device mode
- Built-in Cap Sense Key controller
- 10-bit ADC for analog sampling
- External wake up/interrupt on all GPIOs

PMU

- Low voltage LDO for internal digital and analog circuit supply
- 3uA current consumption in the soft-off mode
- Built-in LDO for the core, I/O, Bluetooth and flash
- VBAT is 2.2V to 5.5V
- VDDIO is 2.2V to 3.6V

Packages

- QFN40(5mm*5mm)

Temperature

- Operating temperature: -40°C to +85°C
- Storage temperature: -65°C to +150°C

Applications

- Bluetooth Mono Sound Box
- Bluetooth TWS charging Box



Confidential

The information contained herein is the exclusive property of JIELI and shall not be distributed, reproduced, or disclosed in whole or in part without prior written permission of JIELI.

1、 Pin Definition

1.1 Pin Assignment

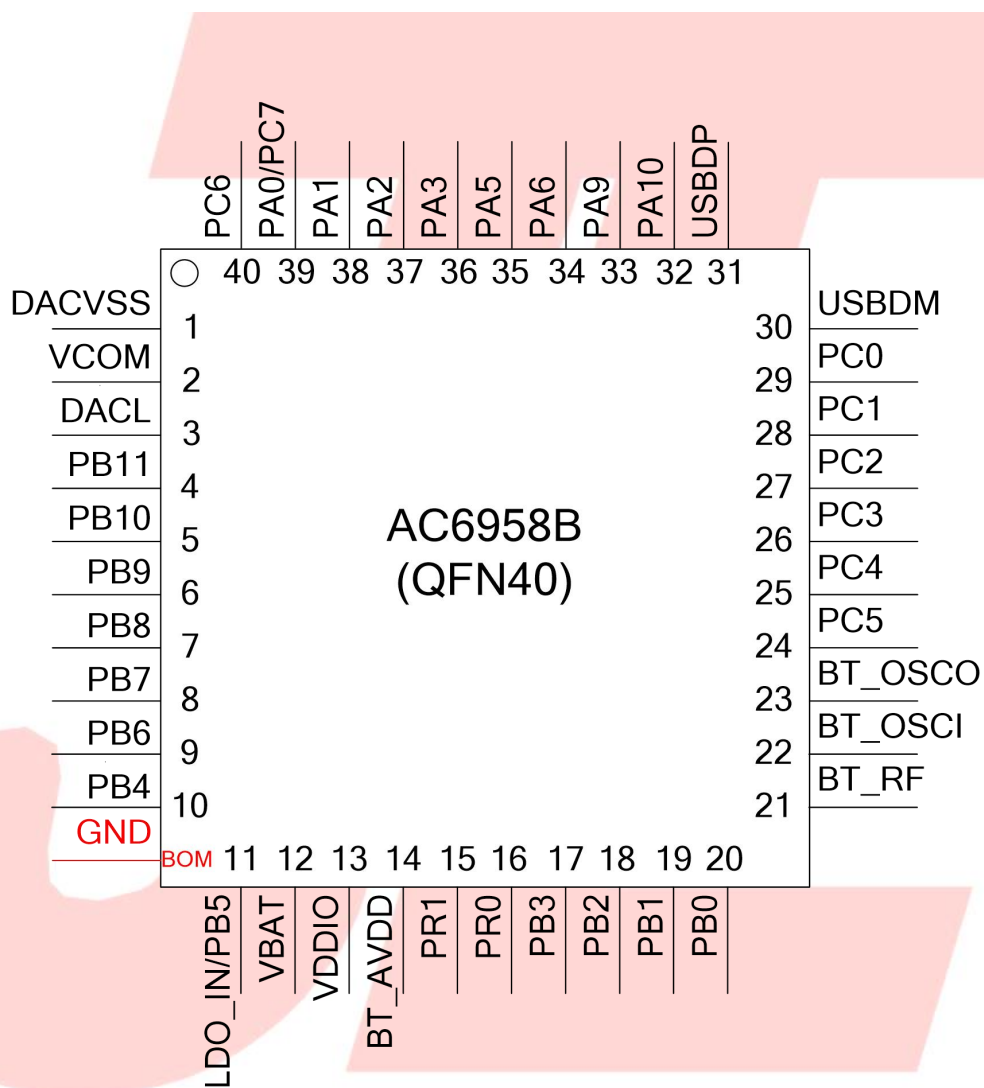

Figure 1-1 AC6958B Package Diagram

1.2 Pin Description

Table 1-1 AC6958B Pin Description

PIN NO.	Name	I/O Type	Drive (mA)	Function	Other Function
1	DACVSS	P	/		DAC Ground
2	VCOM	P	/		DAC Reference
3	DACL	O	/		DAC Left Channel
4	PB11	I/O	/	GPIO	SDPG:SDC Power Gate; SPDIF_OUT: Sony/Philips Digital Interface Out
5	PB10	I/O	/	GPIO	SD0CMDDB: SD0 Command (B); AMUX2R: Analog Channel2 Right; SPI2DOA: SPI2 Data Out(A); ADC9: ADC Input Channel 9; UART2RXC: Uart2 Data In(C); PWMCH3L: Motor PWM Channel3(L);
6	PB9	I/O	/	GPIO	SD0CLKB: SD0 Clock(B); AMUX2L: Analog Channel2 Left; SPI2CLKA: SPI2 Clk(A); CAP0: Timer0 Capture; UART2TXC: Uart2 Data Out(C); PWMCH3H: Motor PWM Channel3(H);
7	PB8	I/O	/	GPIO	SD0DAT0B: SD0 Data0(B); AMUX1R: Analog Channel1 Right; SPI2_DIA: SPI2 Data In(A); ADC8: ADC Input Channel 8; CLKOUT1: Clk Out1;
8	PB7	I/O	/	GPIO	AMUX1L: Analog Channel1 Left;
9	PB6	I/O	/	GPIO	SD1CLKB: SD1 Clock(B); IIC_SDA_C: IIC SDA(C); TMR3: Timer3 Clock Input; UART0RXB: Uart0 Data In(B); PWMCH2L: Motor PWM Channel2 (L);
10	PB4	I/O	/	GPIO	SD1DAT0B: SD1 Data0(B); IIC_SCL_C: IIC SCL(C); ADC7: ADC Input Channel 7; UART0TXB: Uart0 Data Out(B); LVD: Low Voltage Detect Input; PWMCH2H: Motor PWM Channel2 (H);
11	LDO_IN	P	/		Battery Charge Input

Confidential

The information contained herein is the exclusive property of JIELI and shall not be distributed, reproduced, or disclosed in whole or in part without prior written permission of JIELI.

	PB5	I/O	/	GPIO (High Voltage Resistance) *type1	SD1CMDB: SD1 Command (B); PWM3: Timer3 PWM Output; CAP1: Timer1 Capture; UART0TXC: Uart0 Data Out(C); UART0RXC: Uart0 Data In(C);
12	VBAT	P	/		Power Supply
13	VDDIO	P	/		IO Power 3.3v
14	BT_AVDD	P	/		BT Power
15	PR1	I/O	/	RTCIO1 *type1	OSCO_32K
16	PR0	I/O	/	RTCIO0 *type1	OSCI_32K
17	PB3	I/O	/	GPIO	PWM2: Timer2 PWM Output; ADC6: ADC Input Channel 6;
18	PB2	I/O	/	GPIO (High Voltage Resistance)	SPI1DIA: SPI1 Data In(A); PWMCH1L: Motor PWM Channel1 (L);
19	PB1	I/O	/	GPIO (pull up)	Long Press Reset; SPI1DOA: SPI1 Data Out(A); ADC5: ADC Input Channel 5; TMR2: Timer2 Clock Input; UART1RXA: Uart1 Data In(A);
20	PB0	I/O	/	GPIO (High Voltage Resistance)	SPI1CLKA: SPI1 Clock(A); UART1TXA: Uart1 Data Out(A); PWMCH1H: Motor PWM Channel1(H);
21	BT_RF	/	/		BT Antenna
22	BT_OSCI	I	/	OSC In	
23	BT_OSCO	O	/	OSC Out	
24	PC5	I/O	/	GPIO	SD1CLKA: SD1 Clock(A); SPI1DOB: SPI1 Data Out(B); UART2RXD: Uart2 Data In(D); IIC_SDA_B: IIC SDA(B); ADC13: ADC Input Channel 13; PWMCH5L: Motor PWM Channel5(L);
25	PC4	I/O	/	GPIO	SD1CMDA: SD1 Command(A); SPI1CLKB: SPI1 Clock(B); UART2TXD: Uart2 Data Out(D); IIC_SCL_B: IIC SCL(B); ADC10: ADC Input Channel 10; PWMCH5H: Motor PWM Channel5(H);
26	PC3	I/O	/	GPIO	SD1DAT0A: SD1 Data0(A); SPI1DIB: SPI1 Data In(B);

Confidential

The information contained herein is the exclusive property of JIELI and shall not be distributed, reproduced, or disclosed in whole or in part without prior written permission of JIELI.

27	PC2	I/O	/	GPIO	SD1DAT1A: SD1 Data1(A); Touch12: Touch Input Channel 12; FPIN5: Motor Auto-Stop Protective Pin5;
28	PC1	I/O	/	GPIO	SD1DAT2A: SD1 Data2(A); Touch11: Touch Input Channel 11; UART1RXB: Uart1 Data In(B); FPIN4: Motor Auto-Stop Protective Pin4;
29	PC0	I/O	/	GPIO	SD1DAT3A: SD1 Data3(A); ALNK1_SCLK: Audio Link Serial Clock; Touch10: Touch Input Channel 10; UART1TXB: Uart1 Data Out(B); FPIN3: Motor Auto-Stop Protective Pin3;
30	USBDM	I/O	/	USB Negative Data (pull down) *type1	UART1RXD: Uart1 Data In(D); IIC_SDA_A: IIC SDA(A);
31	USBDP	I/O	/	USB Positive Data (pull down) *type1	UART1TXD: Uart1 Data Out(D); IIC_SCL_A: IIC SCL(A); ADC12: ADC Input Channel 12;
32	PA10	I/O	/	GPIO	SD0CLKA: SD0 Clock(A); ADC3: ADC Input Channel 3; SPDIF_IN_B: Sony/Philips Digital Interface Input(B) TMR1: Timer1 Clock Input; Touch9: Touch Input Channel 9; UART2RXB: Uart2 Data In(B); PWMCH4L: Motor PWM Channel4(L);
33	PA9	I/O	/	GPIO	SD0CMA: SD0 Command(A); SPDIF_IN_A: Sony/Philips Digital Interface Input(A) Touch8: Touch Input Channel 8; UART2TXB: Uart2 Data Out(B); PWMCH4H: Motor PWM Channel4(H);
34	PA6	I/O	/	GPIO	ADC2: ADC Input Channel 2; IIC_SDA_D: IIC SDA(D); Touch6: Touch Input Channel 6; UART0RXA: Uart0 Data In(A);

Confidential

The information contained herein is the exclusive property of JIELI and shall not be distributed, reproduced, or disclosed in whole or in part without prior written permission of JIELI.

35	PA5	I/O	/	GPIO	SD0DAT0A: SD0 Data0(A); ADC1: ADC Input Channel 1; IIC_SCL_D: IIC SCL(D); Touch5: Touch Input Channel 5; PWM0: Timer0 PWM Output; UART0TXA: Uart0 Data Out(A);
36	PA3	I/O	/	GPIO	Touch3: Touch Input Channel 3; UART2RXA: Uart2 Data In(A);
37	PA2	I/O	/	GPIO	Touch2: Touch Input Channel 2; UART2TXA: Uart2 Data Out(A); CAP3: Timer3 Capture;
38	PA1	I/O	/	GPIO	AMUX0R: Analog Channel0 Right; Touch1: Touch Input Channel 1; ADC0: ADC Input Channel 0; UART1RXC: Uart1 Data In(C); PWMCH0L: Motor PWM Channel0(L);
39	PC7	I/O	/	GPIO	MIC_BIAS: Microphone Bias Output
	PA0	I/O	/	GPIO	AMUX0L: Analog Channel0 Left; Touch0: Touch Input Channel 0; CLKOUT0: UART1TXC: Uart1 Data Out(C); PWMCH0H: Motor PWM Channel0(H);
40	MIC	I	/		MIC: Microphone Input Channel;

Note:

*type1: The GPIO is uncontrollable during the initial process

Confidential

The information contained herein is the exclusive property of JIELI and shall not be distributed, reproduced, or disclosed in whole or in part without prior written permission of JIELI.

2、Electrical Characteristics

2.1 Absolute Maximum Ratings

Table 2-1

Symbol	Parameter	Min	Max	Unit
Tamb	Ambient Temperature	-40	+85	°C
Tstg	Storage temperature	-65	+150	°C
VBAT	Supply Voltage	-0.3	+5.5	V
LDO_IN	Charger Voltage	-0.3	+5.5	V
V _{3.3IO}	3.3V IO Input Voltage	-0.3	+3.6	V

2.2 PMU Characteristics

Table 2-2

Symbol	Parameter	Min	Typ	Max	Unit	Test Conditions
VBAT	Voltage Input	2.2	3.7	5.5	V	
LDO_IN	Charger Voltage	4.5	5.0	5.5	V	
V _{3.3}	Voltage output	—	3.3	—	V	VBAT = 4.2V, 100mA loading
V _{BT_AVDD}	Voltage output	—	1.3	—	V	VBAT=4.2V, 100mA loading
I _{L3.3}	Loading current	—	—	150	mA	VBAT = 4.2V

2.3 Battery Charge

Table 2-3

Symbol	Parameter	Min	Typ	Max	Unit	Test Conditions
LDO_IN	Charge Input Voltage	4.5	5	5.5	V	—
V _{Charge}	Charge Voltage	4.15	4.2	4.25	V	—
I _{Charge}	Charge Current	20	—	320	mA	Charge current at fast charge mode
I _{Trickl}	Trickle Charge Current	20	45	70	mA	V _{BAT} < V _{Trickl}

Confidential

The information contained herein is the exclusive property of JIELI and shall not be distributed, reproduced, or disclosed in whole or in part without prior written permission of JIELI.

2.4 IO Input/Output Electrical Logical Characteristics

Table 2-4

IO input characteristics						
Symbol	Parameter	Min	Typ	Max	Unit	Test Conditions
V _{IL}	Low-Level Input Voltage	-0.3	–	0.3* VDDIO	V	VDDIO = 3.3V
V _{IH}	High-Level Input Voltage	0.7* VDDIO	–	VDDIO+0.3	V	VDDIO = 3.3V
IO output characteristics						
V _{OL}	Low-Level Output Voltage	–	–	0.33	V	VDDIO = 3.3V
V _{OH}	High-Level Output Voltage	2.7	–	–	V	VDDIO = 3.3V

2.5 Internal Resistor Characteristics

Table 2-5

Port	General Output	High Drive	Internal Pull-Up Resistor	Internal Pull-Down Resistor	Comment
PA1~PA12 PB1、PB3、PB4 PB8~PB10 PC0~PC5	8mA	24mA	10K	10K	1、PB1 default pull up 2、USBDM & USBDP default pull down 3、PB0, PB2, PB5 are high voltage resistance to 5V 4、internal pull-up/pull-down resistance accuracy ±20%
(driving low) PB11, PC7	8mA	24mA	10K	10K	
(driving high)	8mA	64mA			
PB0、PB2 PB5	8mA		10K	10K	
PR0、PR1	8mA		10K	10K	
USBDP	4mA		1.5K	15K	
USBDM	4mA		180K	15K	

2.6 DAC Characteristics

Table 2-6

Parameter	Min	Typ	Max	Unit	Test Conditions
Frequency Response	20	–	20K	Hz	1KHz/0dB 10Kohm loading With A-Weighted Filter
THD+N	–	-75	–	dB	
S/N	–	95	–	dB	
Crosstalk	–	-90	–	dB	
Output Swing		1		Vrms	
Dynamic Range		90		dB	1KHz/-60dB 10Kohm loading With A-Weighted Filter
DAC Output Power			20	mW	32ohm loading

2.7 ADC Characteristics

Table 2-7

Parameter	Min	Typ	Max	Unit	Test Conditions
Dynamic Range		89		dB	Fsample=44.1kHz Fin=1KHz 2mVpp Input
S/N	–	90	91	dB	Fsample=44.1kHz Fin=1KHz 1.2Vpp Input
THD+N	–	-70	–	dB	
Crosstalk	–	-80	–	dB	

2.8 BT Characteristics

2.8.1 Transmitter

Basic Data Rate

Table 2-8

Parameter	Min	Typ	Max	Unit	Test Conditions
RF Transmit Power		4	6	dBm	25°C, Power Supply VBAT=4.2V 2441MHz
RF Power Control Range		20		dB	
20dB Bandwidth		950		KHz	
Adjacent Channel	+2MHz	-40		dBm	
	-2MHz	-38		dBm	
Transmit Power	+3MHz	-44		dBm	
	-3MHz	-35		dBm	

Confidential

The information contained herein is the exclusive property of JIELI and shall not be distributed, reproduced, or disclosed in whole or in part without prior written permission of JIELI.

Enhanced Data Rate**Table 2-9**

Parameter		Min	Typ	Max	Unit	Test Conditions
Relative Power			-1		dB	25°C, Power Supply VBAT=4.2V 2441MHz
$\pi/4$ DQPSK Modulation Accuracy	DEVM RMS		6		%	
	DEVM 99%		10		%	
	DEVM Peak		15		%	
Adjacent Channel	+2MHz		-40		dBm	
	-2MHz		-38		dBm	
Transmit Power	+3MHz		-44		dBm	
	-3MHz		-35		dBm	

2.8.2 Receiver**Basic Data Rate****Table 2-10**

Parameter		Min	Typ	Max	Unit	Test Conditions
Sensitivity			-90		dBm	25°C, Power Supply VBAT=4.2V 2441MHz
Co-channel Interference Rejection			-13		dB	
Adjacent Channel	+1MHz		+5		dB	
	-1MHz		+2		dB	
	+2MHz		+37		dB	
Interference Rejection	-2MHz		+36		dB	
	+3MHz		+40		dB	
	-3MHz		+35		dB	

Enhanced Data Rate**Table 2-11**

Parameter		Min	Typ	Max	Unit	Test Conditions
Sensitivity			-90		dBm	25°C, Power Supply VBAT=4.2V 2441MHz
Co-channel Interference Rejection			-13		dB	
Adjacent Channel	+1MHz		+5		dB	
	-1MHz		+2		dB	
	+2MHz		+37		dB	
Interference Rejection	-2MHz		+36		dB	
	+3MHz		+40		dB	
	-3MHz		+35		dB	

Confidential

The information contained herein is the exclusive property of JIELI and shall not be distributed, reproduced, or disclosed in whole or in part without prior written permission of JIELI.

3、 Package Information

3.1 QFN40(5mm×5mm)

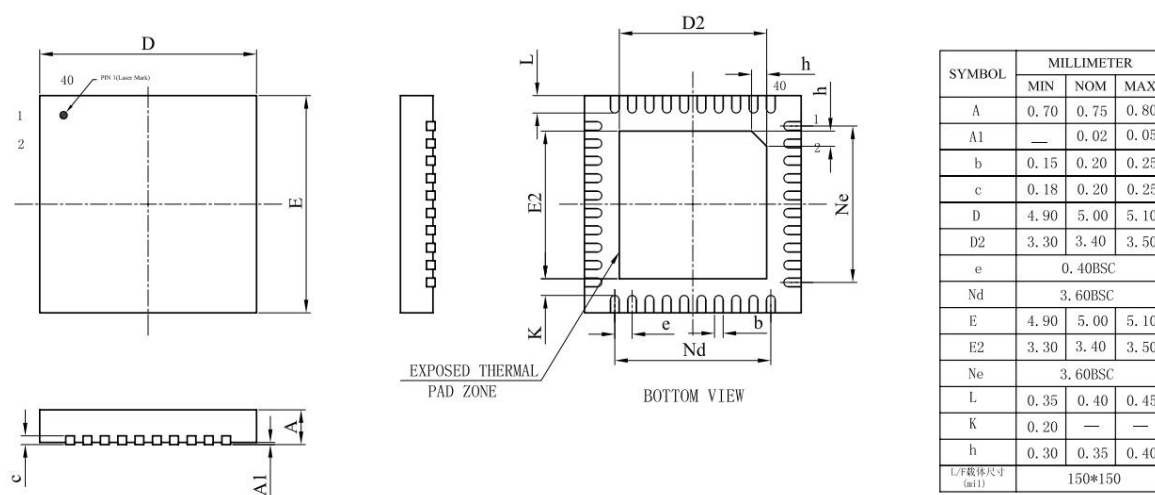

Figure 3-1 AC6958B_QFN40 Package

4、 Revision History

Date	Revision	Description
2020.04.29	V1.0	Initial Release
2022.06.29	V1.1	Update Bluetooth Vision and profiles
2023.01.11	V1.2	Update Pin Description
2025.01.09	V1.4	Update Bluetooth Vision and profiles
2026.03.23	V1.5	Update PMU Characteristics
2026.04.07	V1.6	Update PMU Characteristics